

# PRESSURE SENSORS

# APPLICATIONS

## ● Atmospheric pressure confirmation of chamber

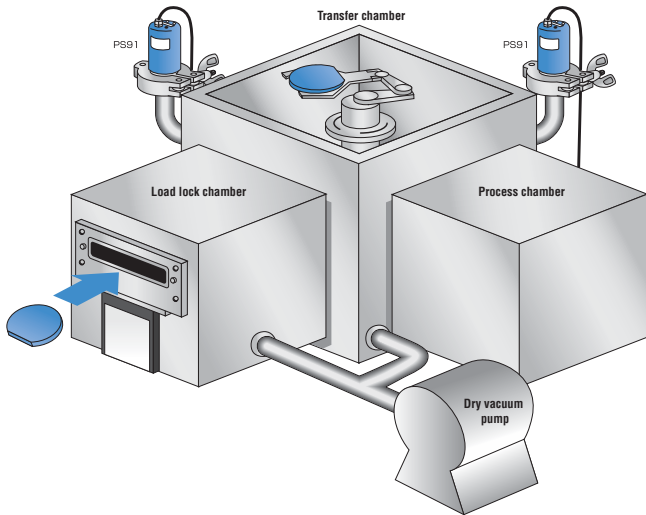

## ● Suction detection

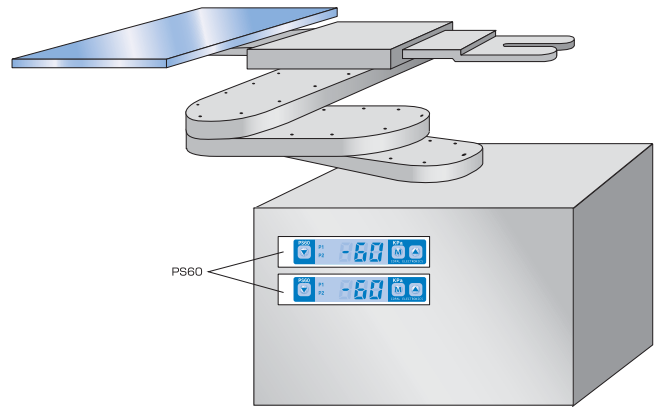

## ● Clogging detection in strainer

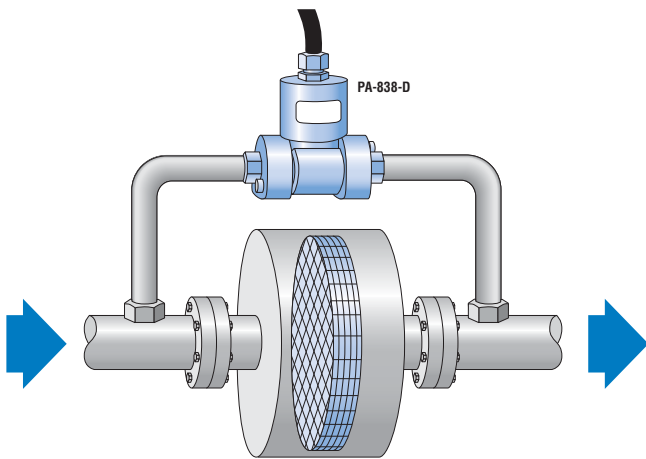

## ● Pressure sensing for water vapor

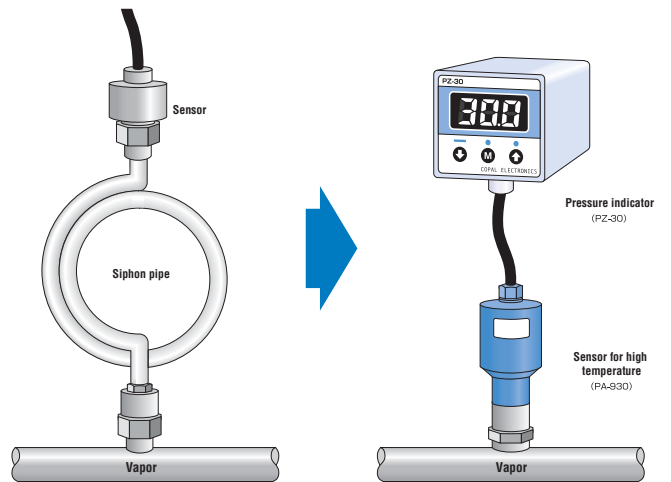

# APPLICATIONS

## PRESSURE SENSORS

### ● Dialysis system

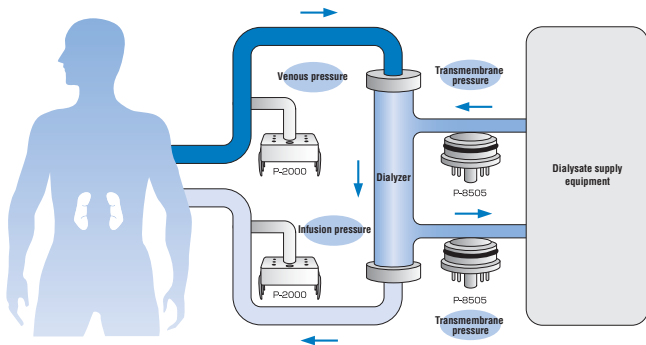

### ● Detection of vacuum level for blood analyzing apparatus

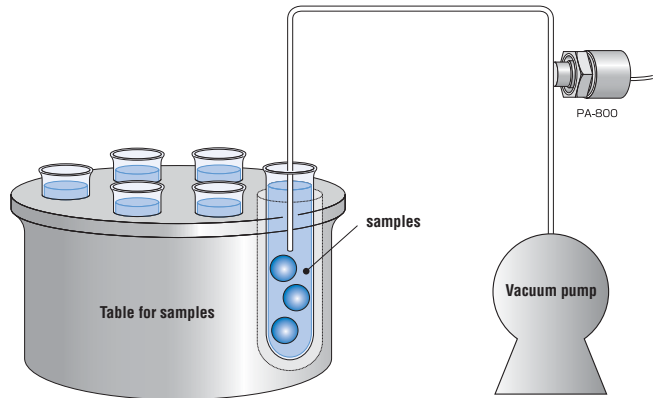

### ● Detection of foreign particle by fraise

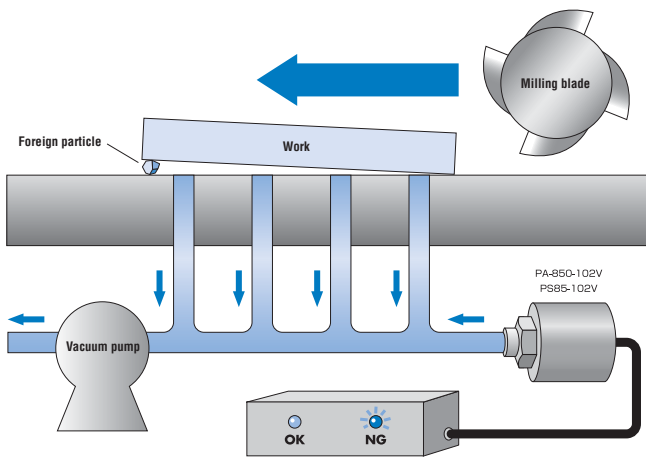

### ● Measuring of water level

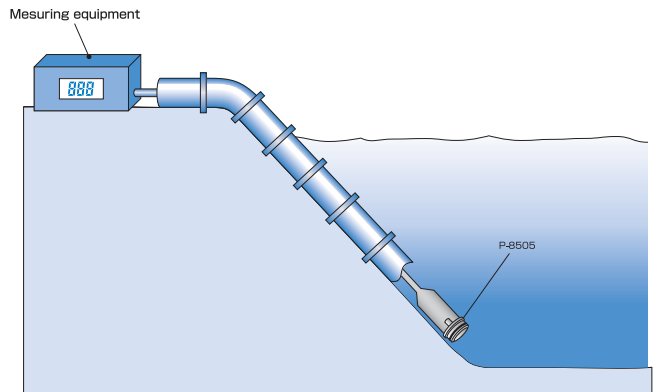

**SCIGATE AUTOMATION (S) PTE LTD**

No.1 Bukit Batok Street 22 #01-01 Singapore 659592

Tel: (65) 6561 0488

Fax: (65) 6562 0588

Email: sales@scigate.com.sg

Web: www.scigate.com.sg

Business Hours: Monday - Friday 8.30am - 6.15pm